

## INTEGRATION OF PV WITH DIFFERENTIAL SYSTEM FOR ENHANCING THE ALL DAY EFFICIENCY

Puja Bharti<sup>1</sup>, Priyanka Gaur<sup>2</sup>  
<sup>1</sup>M.Tech. (ECE), <sup>2</sup>Asst. Prof. Dept. of ECE, AITM, Palwal

**ABSTRACT:** Hybrid Solar System is an energy system that combines solar energy with a photovoltaic system with a different power source for power generation. A typical type of hybrid PV hybrid plant, which combines PV generators and diesel or diesel generators, because PV does not cost at least some and preferably deals in the grid. The diesel generator is used to continuously fill the current distance of PVC and the current generation of energy generated by the photoelectric system. . In fact, the traditional form of morphology is the maximum cost of photovoltaic units and wind turbines at the lowest possible cost. However, the maximum battery capacity cannot be considered or found through a complete search between potential spaces requiring a large amount of calculations. The main objective of paper is to implement an energy system which is a combination of PV and air power. Step by step study and modify photovoltaic cells, solar panels and voltages depending on the characteristic and environmental conditions, and how to study the effects of different temperatures and radiation. We believe that wind voltage and current deformation are sinusoidal. The photo current is almost constant; it is also true that the PV voltage 24V remains constant during the inspection period. We can conclude that the control strategy can monitor battery voltage.

**Keyword:** Solar hybrid power, diesel generators, PV system, hybrid system, MATLAB Software.

### I. INTRODUCTION TO HYBRID SYSTEM

There are many renewable energy sources like solar, wind, tidal and hydro energy. In these renewable energy sources, solar and wind energy are the fastest growing energy sources in the world. In the presence of pollution costs, energy conversion is performed by wind turbine and photovoltaic cells. The demand for electricity is rising rapidly. However, available basic loads of plants cannot supply electricity on demand. Therefore, these energy sources can be used for the difference between supply and demand during the heavy load. This small independent power generation system can also be used in remote areas, where traditional electricity production is not available. This paper studies the Hybrid Power generation model of wind and solar energy. Hybrid systems are more beneficial because the single power generation system is not completely reliable. When a system is closed, another system can provide power. The block diagram of the entire hybrid system is shown in Fig 1.1.

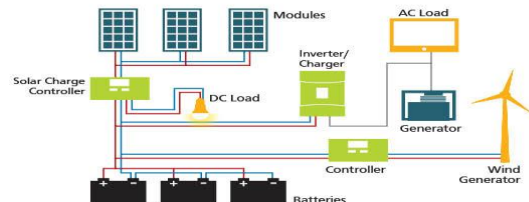

Fig 1.1: Block diagram of hybrid system

Contains PV and air systems on the entire hybrid system. The solar system is solar-powered, which is very common in nature. Photovoltaic modules, Maximum Power Point Tracking system, have a built-in photovoltaic energy system. The light incident on the PV cell turns from a solar collector in electrical energy. The maximum power point tracking system can maximize the maximum power using the P&O algorithms. AC converter is used to convert AC voltage to DC.

### II. OBJECTIVES

The main objective of the paper is to implement a power system that is a hybrid of both Photovoltaic and wind powers. The step by step objectives are

- To study and model PV cell, PV array and PV panels.
- To study the characteristic curves and effect of variation of environmental conditions like temperature and irradiation on them.
- To study the PV module's behavior under partial shading condition.
- To trace the maximum power point of operation the PV panel irrespective of the changes in the environmental conditions.
- To study and simulate the wind power system and track its maximum power point implement hybrid system.

### 2.1 BACKGROUND

In 1839, French physicist Edmund Becquerel proposed that few materials could produce electricity when exposed to the sunlight, But Albert Einstein explained the photoelectric effect and nature of light in 1905. The photoelectric effect states that when the photon or sunlight strikes on the metal surface flow of electrons will take place. Later photoelectric effect became the primary principle of photovoltaic power generation technology. The first photovoltaic module was made by Bell Laboratories in 1954.

### III. PHOTO CELL

Solar cells are electronic devices that convert sunlight directly into electrical energy. When incident light on the solar cell, generates current and voltage for generating electricity as shown in Fig 3.1. This is the first thing in which the absorption of light electrons increases high energy, and second, the higher energy electron moves from the solar cell to the external circuit. Then electrons use their energy in the external circuit and return to the solar cell. Various materials and processes may potentially meet photovoltaic energy conversion requirements, but in practice, all photovoltaic energy conversion uses semi-conductor material in the form of p-n junction.

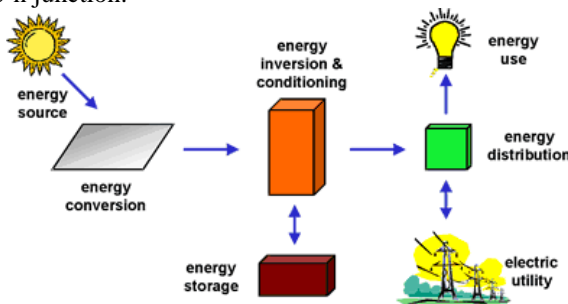

Fig 3.1: Actual understanding of PV system

The basic steps in the operation of a solar cell are:

- ✓ The generation of light-generated carriers;
- ✓ The collection of the light-generated carries to generate a current;
- ✓ The generation of a large voltage across the solar cell; and
- ✓ The dissipation of power in the load and in parasitic resistances.

### IV. HYBRID ENERGY SYSTEM ON MATLAB IMPLEMENTATION

Intermittent energy resources and energy resources unbalance are the most important reason to install a hybrid energy supply system. The Solar PV wind hybrid system suits to conditions where sunlight and wind has seasonal shifts. As the wind does not blow throughout the day and the sun does not shine for the entire day, using a single source will not be a suitable choice. A hybrid arrangement of combining the power harnessed from both the wind and the sun and stored in a battery can be a much more reliable and realistic power source. The load can still be powered using the stored energy in the batteries even when there is no sun or wind. Hybrid systems are usually built for design of systems with lowest possible cost and also with maximum reliability. The high cost of solar PV cells makes it less competent for larger capacity designs. This is where the wind turbine comes into the picture, the main feature being its cheap cost as compared to the PV cells. Battery system is needed to store solar and wind energy produced during the day time. During night time, the presence of wind is an added advantage, which increases the reliability of the system. In the monsoon seasons, the effect of sun is less at the site and thus it is apt to use a hybrid wind solar system.

### V. RESULT AND SIMULATION WORK

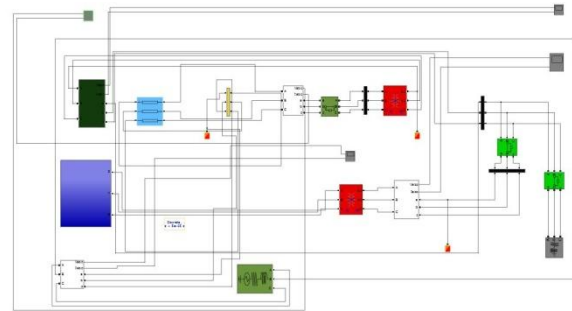

Fig 5.1 Basic Layout

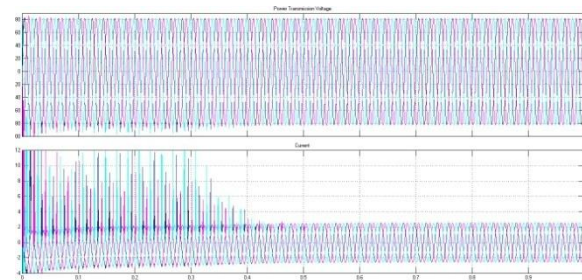

Fig5.2: Three phase VI measurement (HybridSystem)

Experimental results presented in this section are obtained from a hybrid system using MATLAB simulation model as shown in Fig 5.1. The following data was obtained during the operation of data acquisition, with a temperature of 26 ° C, wind speed 9.2 m / s and irradiation of 612 W / M<sup>2</sup>. The results using MATLAB software are shown in above Figure 5.2). We realized that the wind voltage and the current form are sinusoidal. PV current is almost constant; it is also true for PV voltage that remains continuous for whole day observation period of 24 V. We can conclude that the control strategy can efficiently and maintain battery voltage constant.

### VI. CONCLUSION

In this Research, identification and implementation of hybrid photovoltaic/wind/battery system have been proposed. The proposed system is simple due to the reduced number of its components and it is accurate due to its exact of electronic circuits. We have used MATLAB Software which allows a real-time acquisition of electrical parameters. Data acquisition card is chosen to perform an acquisition of different voltages and currents sensors of the global system. In order to achieve this, we realized the different sensors to use MATLAB processes the signals and displays the expected values on a computer screen. The power management strategy proposed is simple. It has been studied to manage the power flow of energy systems and battery to supply the load demand. It clearly shows that the proposed hybrid system and its management control strategy are suitable for an implementation in a real application as in electrification or pumping water for standalone areas.

REFERENCES

- [1] Guillermo Velasco-Quesada, Francisco Guinjoan “Electrical PV Array Reconfiguration Strategy for Energy Extraction Improvement in Grid-Connected PV Systems” IEEE Transactions On Industrial Electronics, Vol. 56, No. 11, November 2009 4319 0278-0046/\$26.00 © 2009 IEEE.
- [2] Jonathan Storey, Peter Wilson “Improved Optimization strategy for Irradiance Equalization in Dynamic Photovoltaic Arrays” Manuscript received May 15th, 2012.
- [3] Vijayalekshmy S, Bindu G R, and S Rama “Estimation of Power Losses in Photovoltaic Array Configurations under Passing Cloud Conditions” Proceedings of the World Congress on Engineering 2014 Vol I, WCE 2014, July 2 - 4, 2014, London, U.K. ISBN: 978-988-19252-7-5 ISSN: 2078-0958 (Print); ISSN: 2078-0966 (Online) WCE 2014.
- [4] Saravanan Kaliyaperumal, Sharmeela Chenniyappan “Low cost Dynamic Switching Technique for Improving the Power in Partially Shaded Photo Voltaic Array” International Journal of Control and Automation Vol.9, No.2 (2016), pp.61-70 <http://dx.doi.org/10.14257/ijca.2016.9.2.07> ISSN: 2005-4297 IJCA Copyright © 2016 SERSC.
- [5] Paula dos Santos Vicente, Tales CleberPimenta, and Enio Roberto Ribeiro “Photovoltaic Array Reconfiguration Strategy for Maximization of Energy Production” Hindawi Publishing Corporation International Journal of Photoenergy Volume 2015, Article ID 592383, 11 pages <http://dx.doi.org/10.1155/2015/592383>
- [6] R.L. Josephine, S. Suja, G. Karunambika “Combination of fixed configuration and reconfiguration method for maximum power extraction from PV arrays” advances in Natural and Applied Sciences, 8(20) Special 2014, Pages: 67-72. R.L.Josephine., Department of Electrical and Electronics Engineering, Coimbatore Institute of Technology, Coimbatore, India.
- [7] V. Di Dio, D. La Cascia, C. Rando, G. RiccoGalluzzo “A new control system prototype for the energy production maximization of a unequally irradiated PV system” Copyright © 2011 MC2D & MITI University of Palermo - DIEET (Department of Electrical Electronic and Telecommunications Engineering) VialedelleScienze, Edificio 9, 90128 Palermo.
- [8] F.Z Zerhouni, M.H Zerhouni, M. Zegrar, M.T Benmessaoul, A. BoudgheneStambouli “Increasing The Efficiency Of The Photovoltaic (PV) Array Utilization With Experimental Results” International Conference on Renewable Energies and Power Quality (ICREPQ'14) Cordoba (Spain), 8th to 10th April, 2014 ISSN 2172-038 X, No.12, April 2014.
- [9] D. Picault, B. Raison a, S. Bacha a, J. de la Casa b, J. Aguilera b “Forecasting photovoltaic array power production subject to mismatch losses” Received 16 February 2010; received in revised form 9 April 2010; accepted 10 April 2010 Available online 12 May 2010.