

PROPERTIES OF CONCRETE PREPARED WITH PARTIAL REPLACEMENT OF FINE AGGREGATES WITH RED SAND

Mumtaz Amin¹, Dr. Pooja Sharma², Dr. Rajesh Goyal³, Er. Akib Nabi⁴

¹M.tech Scholar (Structural Engg.) DBU PUNJAB, ²Deptt. Of Civil Engg. Desh Bhagat University

³Astt. Professor, ⁴M.tech Scholar (Structural Engg.) DBU PUNJAB

ABSTRACT: *The aggregate comprises a substantial portion of concrete. Including coarse and fine aggregates it is normally obtained from natural sources. Fine aggregate in India is usually extracted from River. As the demand for concrete production increases, more natural sand is needed. The need for fine aggregate should be addressed in an environmentally friendly manner, considering the diminishing sources of natural sand. Various industrial by-products, such as fly ash, ground granulated blast-furnace slag and silica fume, have been used in concrete to improve its properties. This also enables any environmental issues associated with their disposal. Another material that is available in large quantities and requiring alternative methods of disposal is the Bauxite Residue (Red Sand) from the Bayer process used to extract alumina from bauxite. Enormous quantity of Red Sand is generated worldwide every year posing a very serious and alarming environmental problem. Hence an investigation was carried out to establish its potential utilization as a sand replacement material in concrete. In addition to fresh properties of concrete containing Red Sand up to 100% by mass of Portland cement, mechanical and durability properties were determined. These properties indicated that Red Sand can be used to replace natural sand up to 100% by mass of cement to improve the properties of concrete without detrimentally affecting their physical properties. Combining these beneficial effects with environmental remediation applications, it can be concluded that there are specific applications where concretes containing Red Sand could be used.*

I. INTRODUCTION

1.1 CONCRETE

Concrete is the most commonly used construction material, and the demand for it will increase as the demand for infrastructure development increases. Unfortunately, Ordinary Portland Cement (OPC) production depletes significant amounts of natural resources as it is a high energy-intensive construction material to produce, third only after the production of steel and aluminium. Furthermore, natural aggregate constitutes a substantial portion of traditional concrete. The natural source of coarse aggregate is crushed rock; and fine aggregate is naturally extracted from sand quarries. The production of one tonne of OPC also releases one tonne of carbon dioxide into the atmosphere. The worldwide cement industry is responsible for about 7% (and rising) of the world's total carbon dioxide generation. Apart from environmental issues associated with the concrete industry, traditional concrete is not very durable in harsh

environments, such as exposure to freezing weather, sea water or sulphuric soils. Thus, it is essential to find methods to increase the durability of traditional concrete by using appropriate replacements for concrete constituents; e.g. aggregate. It is now believed that using more durable and less energy intensive construction materials is inevitable for the construction industry.

1.1.1 Importance

It is estimated that the present consumption of concrete in the world is of the order of 10 billion tonnes (12 billion tons) every year. Humans consume no material except water in such tremendous quantities. The ability of concrete to withstand the action of water without serious deterioration makes it an ideal material for building structures to control, store, and transport water. The ease with which structural concrete elements can be formed into a variety of shapes and sizes. This is because freshly made concrete is of a plastic consistency, which permits the material to flow into prefabricated formwork. After a number of hours, the formwork can be removed for reuse when the concrete has solidified and hardened to a strong mass. It is usually the cheapest and most readily available material on the job.

1.2 COMPONENTS OF MODERN CONCRETE

Concrete is a composite material that consists essentially of a binding medium within which are embedded particles or fragments of aggregate. In hydraulic cement concrete, the binder is formed from a mixture of hydraulic cement and water.

1.2.1 Portland Cement

Joseph Aspdin (1779-1835) patented the clay and limestone cement known as Portland cement in 1824. Joseph's son, William Aspdin, used to make the first genuine Portland cement. Portland cement was first used in the civil engineering project by Isambard Kingdom Brunel (1806-1859), as the lining of the Thames Tunnel



Figure 1.1 Ordinary Portland Cement

While cement in one form or another has been around for centuries, the type we use was invented in 1824 in Britain. It was named Portland cement because it looked like the stone quarried on the Isle of Portland. Portland cement is produced by mixing ground limestone, clay or shale, sand and iron ore.

This mixture is heated in a rotary kiln to temperatures as high as 1,600 degrees Celsius. The heating process causes the materials to break down and recombine into new compounds that can react with water in a crystallization process called hydration.

The raw ingredients of Portland cement are iron ore, lime, alumina and silica. These are ground up and fired in a kiln to produce a clinker. After cooling, the clinker is very finely ground. Cement is a finely pulverized, dry, material that by itself is not a binder but develops the binding property as a result of hydration. A cement is called hydraulic when the hydration products are stable in an aqueous environment.

1.2.2 River Sand: Sand has become a very important mineral for the expansion of society. Sand is a naturally occurring granular material composed of finely divided rock and mineral particles. River sand is one of the world's most plentiful resources (perhaps as much as 20% of the Earth's crust is sand) and has the ability to replenish itself. River sand is vital for human well-being & for sustenance of rivers. As a resource, sand by definition is 'a loose, incoherent mass of mineral materials and is a product of natural processes.' These processes are the disintegration of rocks and corals under the influence of weathering and abrasion. When sand is freshly formed the particles are usually angular and sharply pointed but they grow gradually smaller and more rounded as they become constantly worn down by the wind or water.

Importance of river sand in construction

In terms of particle size as used by geologists, sand particles range in diameter from 0.0625 mm (or 1/16 mm) to 2 mm. The most common constituent of sand, in inland continental settings and non-tropical coastal settings, is silica (silicon dioxide, or SiO₂), usually in the form of quartz, which, because of its chemical inertness and considerable hardness, is the most common mineral resistant to weathering.

Sand has become a very important mineral for our society due to its many uses. It can be used for making concrete, filling roads, building sites, brick-making, making glass, sandpapers, reclamations, and etc. It acts as a buffer against strong tidal waves and storm surges by reducing their impacts as they reach the shoreline.

Sand Constitutions

Sand is a naturally occurring granular material composed of finely divided rock and mineral particles

The composition of sand is highly variable, depending on the local rock sources and conditions, but the most common constituent of sand in inland continental settings and non-tropical coastal settings is silica (silicon dioxide, or SiO₂), usually in the form of quartz which because of its chemical inertness and considerable hardness, is the most common mineral resistant to weathering.



Figure 1.2 River Sand

As per ISO 14688 grades sands are classified as fine, medium and coarse with ranges 0.063 mm to 0.2 mm, 0.25 mm to 0.50 mm and 0.63 mm to 2.0 mm respectively.

Sand mining

Sand Mining is a coastal activity referring to the process of the actual removal of sand from the foreshore including rivers, streams and lakes.

Effects of Sand mining

Individuals and private companies are increasingly demanding sand for construction purposes and this has placed immense pressure on sand resources. It is a practice that is becoming an environmental issue as the demand for sand increases in industry and construction.

Sand mining is a direct and obvious cause of erosion, and also impacts the local wildlife. Disturbance of underwater and coastal sand causes turbidity in the water, which is harmful for such organisms as corals that need sunlight. It also destroys fisheries, causing problems for people who rely on fishing for their livelihoods. Erosion problems may worsen especially during severe storms and may also result in the alteration of our shorelines from streams or rivers upstream can reduce water quality for downstream users and poison aquatic life.

Geologists know that uncontrolled sand mining from the riverbed leads to the destruction of the entire river system. If sand and gravel is extracted in quantities higher than the capacity of the river to replenish them, it leads to changes in its channel form, physical habitats and food webs – the river's ecosystem. The removal of sand from the river bed increases the velocity of the flowing water.

1.2.3 Red Sand

Bauxite Residue

As the world largest producer of alumina, Australia generates large amounts of bauxite residue each year. Approximately 15 million tons of bauxite residue are produced by three refineries in Western Australia. Red sand-the coarse fraction of this residue-makes up to one- half of the bauxite residue.

In Uttar Pradesh HINDALCO operates in Renukoot. HINDALCO is the major producer of INDIA's alumina. HINDALCO extracts alumina from bauxite ore at refinery in Renukoot. They produce about 6 million tonnes of alumina each year which is 5% of world production. Aluminum is produced from alumina. Aluminium is a useful metal due to the range of properties it possesses. It has sufficient strength while being lightweight. It is also nontoxic and non-magnetic. It is very corrosion resistant; a workable metal; conducts electricity and reflects heat and light. The aluminium element comprises around 8 percent of the elements in the earth's soils and rocks, but is only found in chemical compounds in nature. Alumina is in turn produced from bauxite ore using the Bayer process, the widely used method for extraction of alumina.

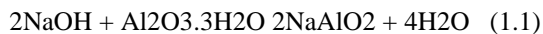

Figure 1.3 Red Sand

The Bayer process was discovered by an Austrian chemist named Karl Bayer in 1887. The Bayer process used by alumina refineries involves four main steps digestion, clarification, precipitation and calcination as follows (Queensland Alumina Limited 2006)

Step 1: Digestion – Dissolving bauxite’s alumina content

To turn bauxite into alumina, firstly the ore is ground and mixed with lime and caustic soda, then this slurry is pumped into high-pressure autoclaves or reactors and heated to form sodium aluminate solution. The reactions are:



Equation 1-1, gives the 1st Stage of Bauxite Digestion

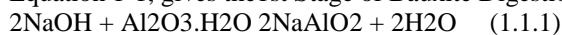

Equation 1-1-1, gives the 2nd Stage Bauxite Digestion

Step 2: Clarification and caustification – Settling out undissolved impurities

Settling allows the removal of waste tailings. Flocculants can be added to improve the rate of mud settling. This is then washed with slacked lime to allow the removal of insoluble carbonate with the mud. The reaction is:

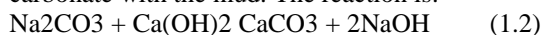

Equation 1-2, gives Caustification

Step 3: Precipitation – Forming alumina crystals

The aluminium oxide which is dissolved by the caustic soda is precipitated out of the pregnant liquor. Precipitation of crystals from the liquor allows alumina to be recovered. Alumina precipitates as the trihydrate ($\text{Al}_2\text{O}_3 \cdot 3\text{H}_2\text{O}$), which is the reverse of the digestion of trihydrate. The reaction is:

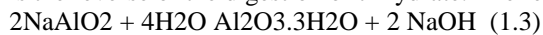

Equation 1-3, gives Precipitation

Step 4: Calcination – High temperature drying of alumina

The aluminium hydrate ($\text{Al}_2\text{O}_3 \cdot 3\text{H}_2\text{O}$) is then washed to remove the process liquor and caustic. This material is then calcined in a fluidised bed calciner to remove both free moisture and chemically bonded water at temperatures around $950\text{--}1100^\circ\text{C}$. Residual bauxite tailings refer to the bauxite waste removed after the digestion and clarification by filtration and decantation.

Bauxite residue can be later separated into two fractions, according to size. The coarse fraction or —red sandll has a particle size in excess of $90\mu\text{m}$. The other portion, —red mudll constitutes approximately half of the residue.

Disposal of this huge amount of residue requires vast areas of land. The disposal process should address environmental

issues considering the fine particles of red sand and prevent the residue from contaminating the ground water and soil. The other challenges are:

The high alkalinity of the generated residue

The costs associated with monitoring and storage

Attempts have been made for disposing bauxite residue in an environmentally friendly manner.

1.3 PROPERTIES OF CONCRETE

When first mixed the water and cement constitute a paste which surrounds all the individual pieces of aggregate to make a plastic mixture. A chemical reaction called hydration takes place between the water and cement, and concrete normally changes from a plastic to a solid state in about 2 hours. Concrete continues to gain strength as it cures. Heat of hydration-is the heat given off during the chemical reaction as the cement hydrates

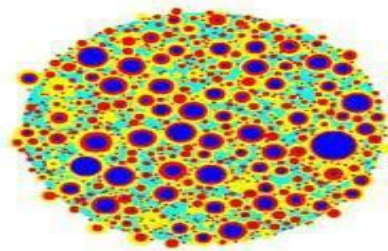

Figure 1.4 Hydration of Cement

Image shown is a two-dimensional slice from a three-dimensional spherical computational volume. Unhydrated cement cores are dark blue. Inner C-S-H product is red. Outer C-S-H product is yellow. Water-filled space is light blue.

AIM OF THE RESEARCH

The aim of this thesis is to evaluate the properties of concrete mixtures made with red sand as a fine aggregate. Making workable, high strength and durable concrete containing red sand can lead to the usage of bauxite residue in the future and paves the way to gradually replacing conventional concrete with less energy-intensive construction materials. Therefore, identifying, testing and enhancing the mechanical and durability features of red sand concrete has been the main objective of this research.

SIGNIFICANCE

This project aims to reduce the impact of bauxite tailings on the environment, through investigating potential industrial applications for this by-product as a construction material. Successfully demonstrating that red sand concrete meets the relevant Indian Standards will effectively convert a byproduct into a valuable construction material. This would significantly reduce the amount of bauxite residue that requires disposal, storing and monitoring.

Furthermore, with the ever increasing demand for quality construction materials, materials such as natural sand are becoming scarce. If red sand can be shown to be an acceptable substitute for natural sand, it will provide valuable new material for the construction industry; and will improve the sustainability of construction operations by reducing the need to mine a natural resource.

II. METHODOLOGY

This project was focused primarily to determine whether red sand and its derivatives can be used as an alternative to natural sand as fine aggregate M20 grade concrete. As stated earlier, the scope of this project was to have Six different mixes, each with a characteristic strength of 20 MPa which is suitable for footing and residential application. The constituents of the concrete consisted of cement, coarse aggregate (10 mm, 12.5 mm and a grading of both), fine aggregate (NS and RS) and water. It was trialed as the only fine aggregate in one concrete batch and in order to provide a comparison, a concrete mix using NS was used as a control mix. NS was chosen as it is already widely accepted and used within the construction industry as a fine aggregate in concrete. Each mix of concrete was tested and evaluated for different physical, mechanical and durability properties.

CONCRETE MIXES

For low strength concrete, a total of six mixes were considered to be batched and tested at the first stage. The Mix 1 was a control mix containing NS and 10 mm and 12 mm aggregate. Mixes 2 to 6 both contained RS with the former using 10 mm and 12 mm coarse aggregate.

CHOSEN TESTS

Each mix underwent a series of tests. These tests were chosen to assess the individual characteristic of the aggregates as well as the workability, strength and durability indicators of the concrete. A complete list of the tests is given in Table 3.1. To assess workability of the fresh concrete mixes, a slump test was used.

Table 3.1 Tests to Assess the Characteristics of the Various Concrete Mixes

Test to assess the characteristics of the various Fine aggregate and Concrete Mixes			
Aggregate Characteristics	Mechanical Properties		Durability
Absorption	Compressive Strength		Water Absorption
Fineness Modulus	Tensile Strength		
Particle Size Distribution			
Specific Gravity			

III. MATERIALS USED

Concrete is a variable material. It is not practical to expect that the characteristics of a concrete mix can be identically replicated on a consistent basis. One of the main reasons for the variability in the concrete is because of the variability in

the materials used to make the concrete. The four basic constituents of ordinary Portland cement concrete are:

- Cement
- Water
- Fine Aggregate
- Coarse Aggregate

There is also a growing market for the use of value adding waste products. These waste products include silica fume, ground granulated blast furnace slag and fly ash. These are used as partial substitutes for cement and also to achieve certain characteristics in the concrete, such as increased plasticity in fresh concrete.

Since the use of red sand in concrete is still relatively unknown, traditional concrete mixes were used, with the materials kept to cement, water, fine aggregate and coarse aggregate. By doing this the effects of red sand could be seen without potential influence from admixtures or cement replacements.

To allow the results to be critically compared to other existing or future research the characteristics of the materials used are shown within this chapter.

Cement

Strength/grade of cement:

Grade of cement 53 grade can influence the mix design. Grade of cement indicates minimum strength of cement in N/mm² tested as per standard conditions laid down by IS codes (OPC 53 grade – IS 12269 – 1987 e.g. a 53 grade cement should give minimum strength of 53 N/mm² at 28 days). Higher the strength of cement, higher is the strength of concrete for the same water/cement ratio. In other words a higher strength of cement permits use of higher water/cement ratio to achieve the same strength of concrete. The IS 10262 - 1982 for mix design gives the different curves of cement based on the actual strength of cement on 28th day. These cement curves give water/cement ratio required to achieve a given target strength. Information on grade of cement may not be as useful as the actual 28days strength of cement. This is because some of the 43 grade cements practically give strengths more than 53N/mm². When a 53-grade cement is stored for a long time, its strength may deteriorate and become equivalent to 33 grade or 43 grade cement. Thus 28 days strength of cement is required to select the cement curve before starting the mix design. Finding the 28 days strengths of cement consumes time. It is not practical in many cases to wait for 28 days strength of cement to start the mix design. In such cases 28 days strength reports of the manufacturers may be used and can be supplemented by accelerated strength of cement found by reference mix method given in IS 10262 Apart from strength of cement, the type of cement e.g. Ordinary Portland Cement, pozzolona cement (blended cement) etc, is also important factor affecting the gain of strength. Blended cements achieve strengths later than Ordinary Portland Cements and require extended curing period. However, use of these elements result in more durable concrete by offering greater resistance to sulphate and chloride attacks.

Initial & Final setting time of cement:

The initial setting time of cement indicates the time after which the cement paste loses its plasticity. Operations like mixing, placing and compaction should be completed well before the initial setting time of cement. The minimum initial setting time specified by IS 456 –2000 (Clause 5.4.1.3 page no 14 and IS 8112-1989 page 2) is 30 minute. Most of the cements produced today give an initial set of more than 60 minutes. Beginning of hardening of cement paste indicates the final setting of cement. The maximum limit for final setting permitted by IS 8112: 1989 (Clause 6.3. page 2) is 600 minute. Most of the cements produced today give a final setting of between 3 to 5 hours. Curing can be started after final setting of cement. The initial setting and the final setting can be extended by use of retarders in order to avoid cold joints when lead-time for placing concrete is longer. A normal General Purpose Portland cement conforming to IS from 53 Grade Cement was used to manufacture concrete mixtures.

Table 3.2 General Specification for Ordinary Portland Cement

oxides	Percent content
CaO	60-67
SiO ₂	17-25
Al ₂ O ₃	3.0-8.0
Fe ₂ O ₃	0.5-6.0
MgO	0.1-4.0
Alkalies (K ₂ O,Na ₂ O)	0.4-1.3
SO ₃	1.3-3.0

Cement was only taken from sealed bags so that pre-exposure to water, potentially affecting the cement, had not taken place.

Fine Aggregate

Gradation of fine aggregates:

The gradation of sand is given by sieve analysis. The sieve analysis is done by passing sand through a set of standard sieves and finding out cumulative passing percentage through each sieve. The IS 383 – 1970 -Table 4, clause 4.3 (refer Annexure I page no 57 of Durocrete Mix Design Manual) classifies fine aggregates in 4 zones starting from zone I representing coarse sand, to zone IV representing the finest sand. The limits of cumulative percentage passing for each sieve for above zones are given in table 4 of IS 383 (refer Annexure I Page 57 of Durocrete Mix Design Manual). The fineness of sand found by sieve analysis governs the proportion of sand in concrete. The overall fineness of sand is given by factor called fineness modulus. Fineness Modulus is given by division of the summation of cumulative retained fractions for standard sieves up to 150-micron sieve size by 100.

The fineness modulus of sand varies from 2.0 to 4.0; higher the FM coarser is

the sand.

Type of Sand - F M

Fine - 2.0 to 2.8

Medium - 2.8 to 3.2

Coarse - 3.2 and above

Specific gravity of fine aggregates:

This is the ratio of solid density of sand particles to the density of water. Higher the specific gravity, heavier is the sand particles and higher is the density of concrete. Conversely a lower specific gravity of sand will result in lower density of concrete. Specific gravity of sand is found with help of pycnometer bottles. The specific gravity of fine aggregates found in Pune region varies from 2.6 to 2.8.

Silt Content by weight:

This is found by wet-sieving of sand and material passing 75 micron sieve is classified as silt. This silt affects the workability of concrete, results in higher water/cement ratio and lower strength. The upper limit for 75-micron sieve in case of sand is 3% by weight. This limit has however been extended to 15% in case of crushed sand in IS 383 – 1970 Table 1. (Refer Annexure I page 59 of Durocrete Mix Design Manual).



Figure 3.2.SSD condition of Red Sand

The fine aggregates were varied in this project to allow comparison. The red sand used in the present study as a fine aggregate were obtained from the Mettur dam, located in Salem by permission of Madras Aluminum Company.

NS with less than 4% slit from local suppliers was used in control mixes as a reference material. All fine aggregates used in this study were prepared in such ways that they were at saturated surface dry (SSD) condition.

Coarse Aggregate

Maximum size of coarse aggregate:

Maximum size of aggregate is the standard sieve size (40mm, 25mm, 20mm, 12.5mm, 10mm) through which at least 90% of coarse aggregate will pass. Maximum size of aggregate affects the workability and strength of concrete.

It also influences the water demand for getting a certain workability and fine aggregate content required for achieving a cohesive mix. For a given weight, higher the maximum size of aggregate, lower is the surface area of coarse aggregates and vice versa. As maximum size of coarse aggregate reduces, surface area of coarse aggregate increases. Higher the surface area, greater is the water demand to coat the particles and generate workability. Smaller maximum size of coarse aggregate will require greater fine aggregate content to coat particles and maintain cohesiveness of concrete mix. Hence 40 mm down coarse aggregate will require much less water than 20 mm down aggregate. In other words for the same workability, 40mm down aggregate will have lower water/cement ratio, thus

higher strength when compared to 20mm down aggregate. Because of its lower water demand, advantage of higher maximum size of coarse aggregate can be taken to lower the cement consumption.

Maximum size of aggregate is often restricted by clear cover and minimum distance between the reinforcement bars. Maximum size of coarse aggregate should be 5 less than clear cover or minimum distance between the reinforcement bars, so that the aggregates can pass through the reinforcement in congested areas, to produce dense and homogenous concrete. It is advantageous to use greater maximum size of coarse aggregate for concrete grades up to M35 where mortar failure is predominant.

Lower water/cement ratio will mean higher strength of mortar (which is the weakest link) and will result in higher strength of concrete. However, for concrete grades above M40, bond failure becomes predominant. Higher maximum size of aggregate, which will have lower area of contact with cement mortar paste, will fail earlier because of bond failure. Hence for higher grades of concrete (M40 and higher) it is advantageous to use lower maximum size of aggregate to prevent bond failure.

Grading of coarse aggregate:

The coarse aggregate grading limits are given in IS383 – 1970 - table 2, Clause 4.1 and 4.2 (Refer Annexure I page 57 of Durocrete Mix Design Manual) for single size aggregate as well as graded aggregate. The grading of coarse aggregate is important to get cohesive & dense concrete.

The voids left by larger coarse aggregate particles are filled by smaller coarse aggregate particles and so on. This way, the volume of mortar (cement-sand-water paste) required to fill the final voids is minimum. However, in some cases gap graded aggregate can be used where some intermediate size is not used. Use of gap-graded aggregate may not have adverse effect on strength. By proper grading of coarse aggregate, the possibility of segregation is minimized, especially for higher workability. Proper grading of coarse aggregates also improves the compactability of concrete.

Shape of coarse aggregate:

Coarse aggregates can have round, angular, or irregular shape. Rounded aggregates because of lower surface area will have lowest water demand and also have lowest mortar paste requirement. Hence they will result in most economical mixes for concrete grades up to M35.

However, for concrete grades of M40 and above (as in case of max size of aggregate) the possibility of bond failure will tilt the balance in favour of angular aggregate with more surface area. Flaky and elongated coarse aggregate particles not only increase the water demand but also increase the tendency of segregation. Flakiness and elongation also reduce the flexural strength of concrete. Specifications by Ministry of Surface Transport restrict the combined flakiness and elongation to 30% by weight of coarse aggregates.

Strength of coarse aggregate:

Material strength of coarse aggregate is indicated by crushing strength of rock, aggregate crushing value, aggregate impact value, aggregate abrasion value. In Maharashtra the coarse

aggregates are made of basalt rock, which has strengths in excess of 100 N/mm². Hence aggregates rarely fail in strength. The IS limits for above tests are given below:

- Aggregate Crushing value
- Aggregate Impact value
- Aggregate abrasion value

Aggregate Absorption:

Aggregate can absorb water up to 2 % by weight when in bone dry state, however, in some cases the aggregate absorption can be as high as 5%. Aggregate absorption is used for applying a correction factor for aggregates in dry condition and determining water demand of concrete in saturated surface dry condition.

In this thesis, Aggregate can be graded or single-sized. Where strict control over the aggregate is required preference is given to single-sized aggregate. IS (Standards India) provides the following definitions for determining the type of aggregate.

Graded aggregate—an aggregate for which more than 15 percent by mass of the total material is retained on at least three consecutive sieves in the set 75.0 mm, 37.5 mm, 26.5 mm, 19.0 mm, 13.2 mm, 9.50 mm, 6.70 mm, 4.75 mm, 2.36 mm, 0.600 mm and 0.075 mm.

Crushed rock which consists of a mixture of fine and coarse aggregates, the coarse fraction being graded, shall be considered graded aggregate for the purpose of this definition.

One-sized aggregate—an aggregate of which at least 60 percent of the mass of the whole material passes a sieve, selected from the set 75.0 mm, 37.5 mm, 26.5 mm, 19.0 mm, 13.2 mm, 9.50 mm, 6.70 mm, 4.75 mm and 3.35 mm, which is immediately less than the nominal size of the aggregate and is retained on the sieve immediately following the selected sieve in this series

Coarse aggregates used in this research were crushed granite, supplied by a local quarry, with nominal maximum size of 10 mm and 12 mm that met the relevant Indian Standard requirements. In order to determine whether the aggregates conformed to the grading requirements under IS, several sieve analyses were conducted. Both the 12 mm and 10 mm coarse aggregates were required to be prepared under surface saturated dry (SSD) conditions as aggregate that is too dry may cause loss of slump. The aggregates were soaked in water for 24 hours before they were allowed to dry. The SSD condition is as its name suggests; the aggregate is saturated but dry on the surface.

Being able to identify a SSD condition requires a little experience; aggregate prepared to SSD conditions are dry on the surface but are still cool to touch. Figure 3.2 shows some aggregate being prepared to SSD conditions.



Figure 3.3 SSD condition of Coarse Aggregate

10 mm aggregate:

For this aggregate 81.4% passes the 9.5 mm sieve (i.e. the sieve immediately less than the nominal aggregate size) and 64.9% is retained on the 6.7 mm sieve (i.e. the sieve immediately following the 9.5 mm sieve). Thus the 10mm aggregate is classified as single-sized (one-sized) aggregate.

The aggregate water absorption test indicated a saturated surface dry (SSD) absorption of 0.30-0.40 % by weight at IS condition.

12 mm aggregate:

This aggregate does not fall under either classification, but more closely fits the description for single-sized aggregate. The 12 mm aggregate is a crushed aggregate, supplied by a local quarry. The water absorption of the aggregate is 0.36% by weight at IS condition.

Water

The water employed in the mixtures was taken from the Anna University of Technology-Trichy, Panruti Campus concrete laboratory which is Perth tap water. This water was also used in the curing tanks.

MIX DESIGN METHODOLOGY

Mix Design

Concrete is an extremely versatile building material because, it can be designed for strength ranging from M10 (10MPa) to M100 (100MPa) and workability ranging from 0 mm slump to 150mm slump. In all these cases the basic ingredients of concrete are the same, but it is their relative proportioning that makes the difference.

Basic Ingredients of Concrete: -

- Cement – It is the basic binding material in concrete.
- Water – It hydrates cement and also makes concrete workable.
- Coarse Aggregate – It is the basic building component of concrete.
- Fine Aggregate – Along with cement paste it forms mortar grout and fills the voids in the coarse aggregates.

Properties desired from concrete in plastic stage: -

- Workability
- Cohesiveness
- Initial set retardation

Properties desired from concrete in hardened stage: -

- Strength
- Imperviousness
- Durability

Concrete mix design is the method of correct proportioning of ingredients of concrete, in order to optimize the above properties of concrete as per site requirements. In other words, we determine the relative proportions of ingredients of concrete to achieve desired strength & workability in a most economical way.

Decision Variables in Mix Design

Water/cement ratio

Cement content

Relative proportion of fine & coarse aggregates

Water/cement ratio

Water to cement ratio (W/C ratio) is the single most important factor governing the strength and durability of concrete. Strength of concrete depends upon W/C ratio rather than the cement content.

Abram's law states that higher the water/cement ratio, lower is the strength of concrete. As a thumb rule every 1% increase in quantity of water added, reduces the strength of concrete by 5%.

A water/cement ratio of only 0.38 is required for complete hydration of cement. (Although this is the theoretical limit, water cement ratio lower than 0.38 will also increase the strength, since all the cement that is added, does not hydrate) Water added for workability over and above this water/cement ratio of 0.38, evaporates leaving cavities in the concrete. These cavities are in the form of thin capillaries. They reduce the strength and durability of concrete. Hence, it is very important to control the water/cement ratio on site. Every extra lit of water will approx. reduce the strength of concrete by 2 to 3 N/mm² and increase the workability by 25 mm.

As stated earlier, the water/cement ratio strongly influences the permeability of concrete and durability of concrete. Revised IS 456-2000 has restricted the maximum water/cement ratios for durability considerations by clause 8.2.4.1, table 5 (Refer Annexure VI page 78 of Durocrete Mix Design Manual).

Cement content

Cement is the core material in concrete, which acts as a binding agent and imparts strength to the concrete. From durability considerations cement content should not be reduced below 300Kg/m³ for RCC. IS 456 –2000 (Refer annexure VI page 78 of Durocrete Mix Design Manual) recommends higher cement contents for more severe conditions of exposure of weathering agents to the concrete. It is not necessary that higher cement content would result in higher strength. In fact latest findings show that for the same water/cement ratio, a leaner mix will give better strength. However, this does not mean that we can achieve higher grades of concrete by just lowering the water/cement ratio. This is because lower water/cement ratios will mean lower water contents and result in lower workability. In fact for achieving a given workability, a certain quantity of water will be required. If lower water/cement ratio is to be achieved without disturbing the workability, cement content will have to be increased.

Relative proportion of fine, coarse aggregates gradation of aggregates

Aggregates are of two types as below:

a. Coarse aggregate (Metal): These are particles retained on standard IS 4.75mm sieve.

b. Fine aggregate (Sand): These are particles passing standard IS 4.75mm sieve.

Proportion of fine aggregates to coarse aggregate depends on following:

- Fineness of sand: Generally, when the sand is fine, smaller proportion of it is enough to get a cohesive

mix; while coarser the sand, greater has to be its proportion with respect to coarse aggregate.

- Size & shape of coarse aggregates: Greater the size of coarse aggregate lesser is the surface area and lesser is the proportion of fine aggregate required and vice versa. Flaky aggregates have more surface area and require greater proportion of fine aggregates to get cohesive mix. Similarly, rounded aggregate have lesser surface area and require lesser proportion of fine aggregate to get a cohesive mix.
- Cement content: Leaner mixes require more proportion of fine aggregates than richer mixes. This is because cement particles also contribute to the fines in concrete.

Mix design of concrete for this research

Detailed steps on the mix design procedure have been included to ensure repeatability of the concrete.

The mix design was based on the method Indian Standard Recommended Guidelines SP: 23-1982. Certain data is necessary when using this Method, the water absorption rates of the fine aggregates and the percentage passing the 600 micron sieve. The mix design based on this method has six stages:

- Find the target mean strength.
- Determine the required water/cement ratio;
- Determine the free-water content;
- Determine the cement content;
- Determine the total aggregate content; and
- Determine the fine and coarse aggregate content.

Despite all mixes using the same water/cement ratio expect the mix M6, to give comparable strengths, each mix still required its own mix design. There are three reasons for this. The first reason is that NS is an uncrushed aggregate whilst RS are crushed aggregates. This is a result of the alumina extraction process which requires the bauxite to be crushed. The mix design method recognizes the differences of crushed and uncrushed aggregates which results in a different mix design.

Illustration:

A mix design for M20 grade of concrete, having moderate workability (Slump range 50mm to 75mm).

Material Properties

Cement 53 grade (Although, actual 28 days compressive strength = 53 N/mm²)

Fine aggregate –

FM. = 5.19 for natural sand 600 micron passing = 72 %

FM. = 3.4 for red sand 600 micron passing = 70 %

Specific gravity for natural sand = 2.6

Specific gravity for red sand = 2.45

Coarse aggregate

10mm - Specific gravity 2.63

Dry Rodded bulk density – 1700 Kg/m³

Find the target mean strength

Concrete is designed for strength higher than characteristic strength as a margin for statistical variation in results and

variation in degree of control exercised at site. This higher strength is defined as the target mean strength. It is calculated as follows:

Target mean strength = Characteristic strength + $K \times \sigma$

K= Himsworth Coefficient is taken as 1.65 for 5 % probability of failure.

σ = Standard deviation

The values of σ are given in IS 10262 for fair, good and very good degree of control. However, IS 456-2000 has given revised values of σ to be considered for mix design. Better the degree of control lesser is the value of σ and lower is the target mean strength. In other words, the 'margin' kept over characteristic strength is more for fair degree of control to that of good degree of control. Say for M20 grade of concrete,

K=1.65 (for 5% failure) and

Standard Deviation= 4.6 N / mm².

Target Mean Strength = $20 + 1.65 \times 4.6$

27.6 N/mm² Determine water/cement ratio

From SP 23-1982, IS method,

Refer annexure II (page no 61)

Water Demand =208 lit for compaction factor of 0.8

Add 3% water for incremental compaction factor of 0.1

Water demand = 208 + 6

214 Lit

Water demand depends on:

Required Workability of concrete: Higher the workability required greater is the water demand.

Aggregate properties: Fineness and silt content of fine aggregate, size, shape and flakiness of coarse aggregate, type of aggregate e.g. crushed, uncrushed.

Use of admixtures: Plasticizers will reduce the water demand

Different mix design methods give empirical relations to find the water demand Say, we want to find water demand for 20 mm maximum size of crushed aggregate and red sand of zone II (F.M. = 3.4) for a slump range of 60 to 80 mm (compaction factor= 0.9)

Cement Content = $214/0.45$

= 475.55Kg/m³

Determine fine and coarse aggregate content

Sand % by volume for zone II sand, compaction factor 0.8

and water cement ratio 0.6 for 20mm down coarse aggregate = 35% (Refer table 2 Annexure III, page no 65 of Durocrete Mix Design Manual)

Corrections

Correction for zone IV sand = -3%

Correction for water/cement ratio of 0.45= - 3%

Net Sand content = 40-6

=34%

Weights of fine and coarse aggregates are calculated as

$V = (W + C/Sc + 1/p(fa/Sfa)) \times 1/1000$

$V = (W + C/Sc + 1/1-p \times (Ca/Sc)) \times 1/1000$

V = Absolute volume of fresh concrete i.e. (gross volume – volume of entrapped Air) = 1-0.03=0.97

W = water demand = 214 Lit

C = cement content = 475.55Kg

p = ratio of fine aggregate to total aggregate =0.34 fa = total quantity of fine aggregate in Kg per m³ ca = total quantity of coarse aggregate in Kg per m³ Sc= Specific Gravity of

Cement =3.15

Sfa= Specific gravity of fine aggregate as red sand=2.45

Sca= Combined Specific Gravity of Coarse aggregate
(Assuming 30% of coarse aggregate is 10mm down
aggregate =2.90 x 0.7 + 2.86x 0.3
=2.89

Fa= 503.99 Kg/m³

Ca =1050.21Kg/m³

The above calculated value for the mix design of RS having
specific gravity 2.45 and w/c ratio of .45 (i.e M6)

Mix design for NS having specific gravity of 2.6and w/c ratio
of .42(M1-M5) is, Correction for zone 1 sand = -1.5%

Correction for water/cement ratio of 0.42= - 2% Net Sand
content = 35-3.5

=31.5%

Weights of fine and coarse aggregates are calculated as $V = (W + C/Sc + 1/p(fa/Sfa)) \times 1/1000$

$V = (W + C/Sc + 1/1-p \times (Ca/Sca)) \times 1/1000$

V = Absolute volume of fresh concrete i.e. (gross volume –
volume of entrapped Air)

1-.02

=0.98

W = water demand = 185.12Lit

C = cement content = 440.76Kg

p = ratio of fine aggregate to total aggregate =0.315 fa = total
quantity of fine aggregate in Kg per m³ ca = total quantity of
coarse aggregate in Kg per m³ Sc= Specific Gravity of
Cement =3.15

Sfa= Specific gravity of fine aggregate as NS=2.6

Sca= Combined Specific Gravity of Coarse aggregate
(Assuming 30% of coarse aggregate is 10mm down
aggregate =2.90 x 0.7 + 2.86x 0.3
=2.89

Fa= 612 Kg/m³

Ca =1148.60Kg/m³

Table 3.3: Mix Quantities Used per cubic meter of Concrete

Mixture No.	Cement Kg/m ³	Fine Aggregate		Coarse Aggregate Kg/m ³	Water Lit/m ³	W/C ratio
		Sand Kg/m ³	Red sand Kg/m ³			
1	440.76	612.00	0.00	1148.60	185.12	0.42
2	440.76	459.00	153.00	1148.60	185.12	0.42
3	440.76	306.00	306.00	1148.60	185.12	0.42
4	440.76	153.00	459.00	1148.60	185.12	0.42
5	440.76	0.00	612.00	1148.60	185.12	0.42
6	475.55	0.00	503.99	1050.21	214.00	0.45

Mix Quantities

Using the mix design method presented in Section 2.5.4,
quantities of cement, water, fine and coarse aggregate were
determined for each of the mixes. Table 3.3 the quantities
used per cubic meter.

Preparation of Material

Saturated surface dry (SSD) condition:

One of the most important aspects of casting the concrete
was to ensure that the aggregates were in a suitable moisture
condition, namely saturated surface-dry (SSD). The reason
for this is that if the aggregate is too wet it will add free
water to the mix, increasing the free-water / cement ratio for
the mix theoretically resulting in a reduced strength. If the
aggregate is too dry it will absorb free-water in the mix,
resulting in a reduced free-water / cement ratio for the mix,
likely reducing the workability. The SSD condition is where
the aggregate is in a state so that it will not give off any
water and will not absorb any water. Aggregate is in this
state when the internal pores of the aggregate are full of
water but the surface of the aggregate is dry.

Coarse aggregate preparation:

Initially the coarse aggregate was brought to the SSD
condition by soaking the aggregate for 24 hours and then
allowing it to air dry to SSD condition. Due to difficulties in
bringing the aggregate to the SSD condition especially in the
winter season an alternative approach was taken. An amount
of aggregate, exceeding the amount required in the mix, was
placed in a sealed container. Approximately 24 hours prior to
casting a sample of approximately 1 kg was taken from the
sealed container, accurately weighed and placed in an oven
at 105°C for a period of 24 hours. The sample was weighed
again and the water content of the aggregate was determined
as a percentage. This value was subtracted from the
percentage of water contained in the aggregate in the SSD
condition, which gives the percentage of water needed to be
added or taken from the aggregate in order for it to be in the
SSD condition. The percentage was converted into a quantity
for the amount of aggregate to be used in the batch and this
was added or subtracted from the free-water content of the
batch.

Fine aggregate preparation:

The red sand was neutralized by the method of washing the
sand by the sea water. The fine aggregate was brought to the
SSD condition in a similar method as for the coarse
aggregate except that all of the fine aggregate was dried and
then water was added to the free-water content of the mix.
The fine aggregate was completely dried by placing it in an
oven, set at 105°C, for at least 72 hours. The ovens used for
drying are shown in Figure 3-7. The amount of water required
to be added, as a percentage, which is the percentage of
water contained in the aggregate in the SSD condition. As
with the coarse aggregate the water was added to the free-
water content of the batch.

Weighing of material

Another critical element in the casting of a batch of concrete
is the measuring out of the materials. In this work weigh

batcher is used, its level & calibration should be checked daily before starting the work. Calibration can easily be checked by preparing sand bags of 25Kg & 5 Kg.

Preparation of Concrete

To mix the materials a tilting drum type mixer with a capacity of 100 litres was used. The mixing procedure was carried out as described in SP 23-1982 Hand Book on Concrete Mixes. Prior to the first batch of each mix the pan was moistened so that free-water was not lost to the pan. The mixer was also thoroughly cleaned out between mixes. All loading of the mixer was done by hand and followed the following sequence:

All coarse aggregate was loaded followed by the fine aggregate;

The aggregates were mixed for a short period of time;

The cement was carefully added in;

The cement was mixed in with the aggregate;

Water was added while mixing was in progress over a 1-2 minute period;

The batch was then mixed for approximately 2 minutes, until it could be seen that everything had been thoroughly combined; and

A slump measurement was taken in accordance with SP 23-1982 Hand Book on Concrete Mixes.

The concrete from the slump test was added back to the mix and the concrete was mixed for approximately 2 minutes.

Casting of and Compaction Concrete Samples

After mixing, the concrete mix was cast into cube moulds of 10×10×10 cm for compressive strength and 15 cm diameter in cross section and 30cm height cylinder moulds for tensile test. The inside of the cylinder and cube was coated with a thin layer of a water-based release agent to facilitate demoulding of the samples after curing.

The compaction of fresh concrete was carried out using sixty hits per layer with a rod. Fresh concrete was cast in three layers in each cube and cylinder. Each layer was compacted by tamping rod for compaction.

The moulds were then covered in plastic sheets in order to prevent loss of moisture. The covered moulds were then transferred to the curing room for 24 hours —preset period before the start of curing at elevated temperatures.

Demoulding and Curing Details

Demoulding was done between 18 and 24 hours from mixing. Care was taken with demoulding to ensure that none of the specimens were damaged. Once the samples had been demoulded they were placed in curing tanks filled with water as in Figure 3-6.

Curing is described as keeping the concrete moist and warm enough so that the hydration of cement can continue. Curing is being given a place of increasing importance as the demand for high quality concrete is increasing.

If curing is neglected in the early period of hydration, the quality of concrete will experience a sort of irreparable loss.

Curing methods may be divided into four categories. They are water curing, membrane curing, application of heat and miscellaneous. We was used water curing such as immersion. High temperature curing was started on the day after casting.

For curing, the moulds were taken to the curing room and placed.

TEST PROCEDURES AND METHODOLOGY

Where possible testing was done in accordance with the applicable Indian Standards. Due to equipment, resources and other restrictions there were instances where the Indian Standards could not be followed. There are also several tests that are not represented by an Indian Standard. As such this chapter presents, in detail, the procedures followed for each test to ensure repeatability.

Particle Size Distribution

Particle size distributions were carried out for all fine and coarse aggregates used in this project in accordance with IS 383-1970, Specification for Coarse and Fine Aggregate from Natural Sources for Concrete.

This section will discuss the methodology for conducting a sieve analysis.

Procedure for Fine Aggregate Sieving

About 2 kg of oven dried fine aggregate was required for the sieve analysis. Eight sieves of 20 cm in diameter were stacked in order, from largest to smallest with the smallest sitting on the bottom.

The sieves aperture sizes used were 4.75mm, 2.36 mm, 1.18mm, 1mm (Figure 3.7), 600 µm, 300 µm, 150 µm, 90µm. The sand sample was then placed in the top sieve and shaking was done by hand until less than 1% of the particles left on each sieve was able to fall through. If it does then the sand left on the sieves that have the extra material on it must be divided into smaller allowable portions and re-sieved hand.



Figure 3.7 Sieve Stack

The mass retained on each sieve was then measured and represented as a percentage of the total sample. The cumulative percentage passing was compared with the grading requirements given in IS 383-1970, Specification for Coarse and Fine Aggregate from Natural Sources for Concrete. For this standard, Natural Sand is taken as uncrushed aggregate with the Red Sand derivatives considered as crushed aggregates. Figure 3.8 show the

particle size distribution of Natural Sand and Red Sand respectively with the finest particles on the left hand side and the coarsest on the right.

pH TEST PROCEDURE

Weigh and place 1kg of soil into the glass beaker. Add 2lit of distilled water to the soil sample. Stir to obtain a soil slurry and then cover with watch glass. The sample must stand for a minimum of one hour, stirring every 10 to 15 minutes. This is to allow the pH of the soil slurry to stabilize. After one hour, the temperature of the sample should be stabilized. Measure the temperature of the sample and adjust the temperature controller of the pH meter to that of the sample temperature.

This adjustment should be done just prior to testing. On meters with an automatic temperature control, follow the manufacturer's instructions. Standardize the pH meter by means of the standard solutions provided. Temperature and adjustments must be performed. Immediately before immersing the electrode(s) into the sample, stir the sample well with a glass rod. Place the electrode(s) into the soil slurry solution and gently turn beaker to make good contact between the solution and the electrode(s). DO NOT place electrode(s) into the soil; only into the soil slurry solution.

The electrode(s) require immersion 30 seconds or longer in the sample before reading to allow the meter to stabilize. If the meter has an auto read system, it will automatically signal when stabilized. Read and record the pH value to the nearest tenth of a whole number. Rinse the electrode(s) well with distilled water, then dab lightly with tissues to remove any film formed on the electrode(s). Caution: Do not wipe the electrodes as this may result in polarization of the electrode(s) and consequent slow response

Pycnometer test

This test is used for finding the specific gravity.

Determine and record the weight of the empty clean and dry pycnometer, W1. Place 1/3 of a dry soil sample in the pycnometer. Determine and record the weight of the pycnometer containing the dry soil, W2. Add distilled water to fill about full of the pycnometer. Soak the sample for 10 minutes and apply a partial vacuum to the contents for 10 minutes, to remove the entrapped air. Stop the vacuum and carefully remove the vacuum line from pycnometer.

Fill the pycnometer with distilled water (to the mark), clean the exterior surface of the pycnometer with a clean, dry cloth. Determine the weight of the pycnometer and contents, W3. Empty the pycnometer and clean it. Then fill it with distilled water only (to the mark). Clean the exterior surface of the pycnometer with a clean, dry cloth. Determine the weight of the pycnometer and distilled water, W4 Empty the pycnometer and clean it.

Workability Test Procedure

A very important characteristic of a concrete is its workability when it is wet (prior to setting into a hardened state). There are two reasons for this. The first is that placement becomes difficult if the concrete is too stiff and it may not be able to be pumped. The second reason is that the concrete may not be able to be compacted adequately thus leading to voids in the hardened concrete.

An increase in voids will lead to a decrease in the durability

of the concrete. This is due mainly to lowered resistance to permeability of water and water borne ions. Also if the concrete is too stiff there is an increased likelihood of the concrete being watered down on site to make placement easier, reducing both the strength and the durability of the concrete.

Figure 3.9 shows the front view and bottom view of the mould that is used for a slump test. The dimensions of the mould as per IS code is 300 mm in height, 100 mm top diameter and 200 mm bottom diameter. This mould is required to be moistened prior to use and is placed on a flat smooth surface.

To conduct a slump test, a person is required to stand on the two plates attached to the bottom of the mould to hold it into place. Once the concrete has been mixed the slump test can begin by placing the freshly batched concrete, with the aid of a conical collar, into the mould. The concrete is placed in three equal layers and once the first layer is placed, a tamping rod 600 mm long, 15 mm in diameter is used to compact the fresh concrete. Compaction requires 25 'blows' with the tamping rod and for each layer, the tamping rod should penetrate just past the previous layer.

The mould is then removed very carefully, being vertically lifted in approximately three seconds, without causing any lateral or torsional displacement of the concrete. The slump is determined by placing the empty mould next to the slumped concrete and measuring the difference in height between the mould and the average height of the top surface of the concrete using a steel ruler. This can be seen in Figure 3.10.

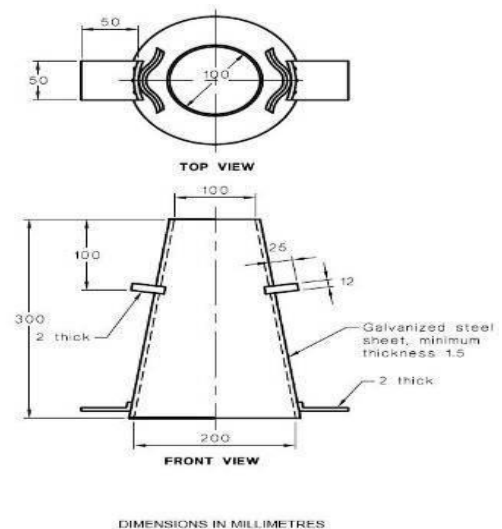

Figure Mould for Slump Test



Figure Slump Test in Progress

Compressive Strength Test Procedure

Testing for compressive strength was based on the method presented in IS 516-1959 Methods of tests for strength of Concrete. All compressive strength tests were done by the Compression Testing Machine.

The procedure used to test the specimens is as follows

- Specimens were removed from the curing tanks on the day of testing and any extra water was wiped off;
- A rubber cap was placed concentrically on the top (rough) surface of the specimen;
- The specimen was placed in the centre of the lower plate on the machine and the upper plate was brought down to sit on the top of the specimen;
- Force was constantly applied to the specimen at a loading rate of 160 kN/min (approximately 20 ± 2 MPa/min until failure); and
- The Compression Testing Machine records the maximum force exerted.

The specimens were generally tested within 30 minutes of being removed from the curing tanks and always tested on a clean, oil and grit free surface. The hydraulic load, applied at 160 kN/min, was monitored throughout the entire test via a load pacer and manually controlled by a dial. The load rate was established gradually, smoothly building up to the 160 kN/min rate to avoid shock loading. The machine accuracy was tested midway through testing and was found to be accurate to 6 kN at a 1000 kN load. Each test consisted of three to three cubes and the compressive strength was taken as the average of all the specimen values.

Indirect Tensile Strength Test Procedure

This test also known as the 'Brazilian Test' or 'Splitting Test' was conducted in the Compression Testing Machine (CTM) as for the compression strength tests. Testing for tensile strength was based on the method presented in IS 5816-1998 Splitting Tensile Strength of Concrete Standards. Testing for indirect tensile strength took place at 3, 7 and 28 days from casting.

The procedure used to test the specimens is as follows

- Specimens were removed from the curing tanks and extra water was wiped off;
- The specimen was placed in a testing jig to ensure that the sample is loaded centrally on its longitudinal axis so that the jig did not bear directly onto the concrete specimen. Hardwood bearing strips was used on the top and bottom of the specimen. As the contact plates of the test machine are smaller than the jig, bearing plates were used between the testing machine plates and the jig;
- The upper plate is brought down to sit on the top of the specimen;
- Force was constantly applied to the specimen at a loading rate of 210 kN/min (1.5 ± 0.15 MPa/min) until the specimen failed; and
- The Compression Testing Machine records the maximum force exerted.

The specimens were generally tested within 30 minutes of

being removed from the curing tanks and always tested on a clean, oil and grit free surface. The hydraulic load, applied at 210 kN/min, was monitored throughout the entire test via a load pacer and manually controlled by a dial.

The load rate was established gradually, smoothly building up to the 210kN/min rate to avoid shock loading.

Aggregate Water Absorption

The water absorption of the aggregates was measured based on the method presented in ASTM C109, Cement Standards and Concrete Standards. The procedure of the test was as follows

- The test sample was placed into water for not less than 24 hours and gently stirred with a rod to remove any trapped air;
- The water was then drained off and the aggregate spread onto a flat surface, then left in warm air (stirring frequently);
- The aggregate was stirred at the same time to achieve uniform Surface-drying;
- The aggregate was placed into a conical mould where it appears to be free flowing. It was tamped 25 times with the tamping tool.
- The mould was vertically lifted and the shape of the aggregate was noted;
- If the cone is slumped in the first attempt, the aggregate was too dry. Conversely, the sample needed to be surface dried further;
- The test was repeated at an interval of 5 to 10 minutes. Depending on the 'slump' of the aggregate cone, the final step was repeated if necessary to reach a Saturated Surface Dry (SSD) condition;
- Once this had been achieved, the mass (m_2) was measured; and
- The sample was then placed on a dish in an oven (105°C) until it reached a constant mass, which was then measured (m_1).

IV. RESULTS AND DISCUSSION

Results presented in this chapter consist of the control mixes plus mixes that incorporated red sand. Results of mechanical properties of the concrete specimens, including compressive, indirect tensile, the durability testing result (water absorption) are presented and discussed. Test results for various mix are presented and discussed.

All bauxite residue derivatives are characterized in terms of chemical analysis, physical properties, mineralogical composition, alkali aggregate reaction, aggregate soundness and other properties. The results obtained from compressive testing for mixes 2-6 (mixes with high proportions of red sand) have been included, the excess water demand the fine red sand concrete mixes required, and hence significant increases in water cement ratio.

Physical Properties

Some physical characteristics of fine aggregates used in this research are summarized in Table (4.1). The similarity of natural sand properties with red sand are noteworthy. Red sand contain pH value of 8.98 where neutralized red sand pH

value given in the table. Due to a higher percent of fines in red sand, its surface area is greater than natural sand and it can be concluded that the workability of concrete mixes incorporating red sand as a fine aggregate.

4.1 Physical Characteristics of Fine Aggregates

Parameters	Specific gravity	Bulk density, [kg/m ³]	Moisture content, [%]	pH
SAND	2.52	1.61	36	7-7.5
RED SAND	2.45	1.43	42	8.07

Table 4.3(a) Grading of NS

Is Sieve Size in mm	Weight Retained (River Sand)	Cumulative Weight Retained For River Sand	Cumulative % Weight Retained For River Sand	Cumulative % Weight Passing For River Sand
4.75	20	20	1	99
2.36	50	70	3.5	96.5
1.18	350	420	21	79
1	180	600	30	70
0.6	610	1210	60.5	39.5
0.3	700	1910	95.5	4.5
0.15	50	1960	98	2
0.09	10	1970	98.5	1.5
<0.09	20	1990	99.5	0.5

Table 4.3(b) Grading of RS

Is Sieve Size in mm	Weight Retained (Red Sand)	Cumulative Weight Retained For Red Sand	Cumulative % Weight Retained For Red Sand	Cumulative % Weight Passing For Red Sand
4.75	0	0	0	100
2.36	0	0	0	100
1.18	15	15	0.75	99.25
1	30	45	2.25	97.75
0.6	90	135	6.75	93.25
0.3	935	1070	53.5	46.5
0.15	665	1735	86.75	13.25
0.09	110	1845	92.25	7.75
<0.09	115	1960	98	2

WORKABILITY OF FRESH CONCRETE

Slump measurements, a common method of workability measurement in practice, were used as indicators of consistency of the concrete in accordance with IS. Workability was also judged through a visual inspection of the concrete mixes during mixing and pouring and a general feel of the practicality of the mixes workability.

Slump Test

Overall, all the mixes did have a moderate workability level but at least this was consistent throughout. Average slump values are shown in Table 4-5. The slump was measured twice, once for each batch. Although IS (Standards India 1997) states that for high slumps exceeding 110 mm a tolerance of ± 30 mm is permitted., these high slumps value were a little too high for practical use in comparison with commercial concrete and would not be accepted in industry. With such a high workability, special care was taken not to over tamping the concrete by the rod to avoid segregation of the concrete. Figure 4-3 shows the average, upper and lower slump values of the mixes.

Table 4.5 Workability Experienced of Concrete Mixes

Mix	M1	M2	M3	M4	M5	M6
Average Slump	85	80	50	65	50	60

Figure Workability of various mix



Table Detail of compressive strength of mixes

RS content %	Mix designation	3 day N/mm ²	7 day N/mm ²	28 day N/mm ²
0	M1	24	30	35
25	M2	25	37.5	40
50	M3	28	39.5	45
75	M4	29.5	39.5	46
100	M5	32	40	54
100	M6	34	45	60.5

SPLIT TENSILE STRENGTH

The tensile strength of concrete is only a fraction of its compressive strength and it is often taken as zero in the design of concrete structures. Despite this there are situations where the ability of concrete to resist low tensile stresses is utilised. One example stated in Concrete Structures (Warner et al. 1998) is the ability of the tensile stress of concrete to control beam deflections —where the tensile stresses contribute significantly to the overall beam stiffness. The tensile reinforcement in concrete does not actually start working until the concrete in that area cracks under tensile stresses, thus transferring the load to the steel. So, while the tensile strength of concrete may be taken as zero in many design calculations for simplicity / conservatism, in reality it does affect the behaviour of concrete structures.

Mixtures M1 to M6 were made with different percentages of red sand. For each mix, specimens were tested for compressive strength after 3, 7 and 28 days after casting. The average of three cylinders was taken as the mean split tensile strength. In 3 days split tensile strength of mix 1 and mix 2 is same but mix 3 is 0.0015% higher than mix 2 and mix 4 is 0.0007% higher than mix 3 and mix 5 is 0.0007% higher than mix 4 and also mix 6 is 0.0007% higher than mix 5 but slump value of the mix is decreased when increasing the red sand content.

In 7 days compressive strength of mix M1, mix M2 is same and mix M5, mix M6 is also same, but mix 3 is 0.0008% higher than mix M2 and mix M4 is 0.0002% higher than mix M3 and mix M5 is 0.0005% higher than mix M5.

In 28 days compressive strength of mix M2 is 0.0035% higher than mix M1 and mix M3 is also 0.0007% higher than mix M2 and mix 4 is 0.0024% higher than mix M3 and mix 5 is 0.0103% higher than mix M4 and also mix M6 is 0.0077% higher than mix M5 but slump value of the mix is decreased when increasing the red sand content. Finally it resulted that the mix M6 have higher split tensile strength when compare to the other mix M5.



Figure Split Tensile Test

Table 4.7 Details of split tensile strength

RS content %	Mix designation	3 day N/mm ²	7 day N/mm ²	28 day N/mm ²
0	M1	2.68	3.39	3.54
25	M2	2.68	3.39	3.89
50	M3	2.83	3.47	3.96
75	M4	2.9	3.49	3.96
100	M5	2.97	3.54	4.10
100	M6	3.04	3.54	4.24

Table: Details of Water Absorption Test for Concrete

Mix No	Water Absorption %
M1	4.21
M2	3.94
M3	3.79
M4	3.47
M5	3.16
M6	3.32

V. CONCLUSION

With natural sand deposits the world over drying up, there is an acute need for a product that matches the properties of natural sand in concrete.

In the last 15 years, it has become clear that the availability of good quality natural sand is decreasing. With a few local exceptions, it seems to be a global trend. Existing natural sand deposits are being emptied at the same rate as urbanization and new deposits are located either underground, too close to already built-up areas or too far away from the areas where it is needed, that is, the towns and cities where the manufacturers of concrete are located.

ENVIRONMENTAL ISSUES

Environmental concerns are also being raised against uncontrolled extraction of natural sand. The arguments are mostly in regards to protecting riverbeds against erosion and the importance of having natural sand as a filter for ground water.

The above concerns, combined with issues of preserving areas of beauty, recreational value and biodiversity, are an integral part of the process of most local government

agencies granting permission to aggregate producers across the world.

This is the situation for the construction industry today and most will agree that it will not change dramatically in the foreseeable future. Crushed aggregate is replacing natural sand and gravel in most countries.

ANALYSIS OF RESULT

The main objective of this research was to investigate the possibility of using the coarse fraction of bauxite residue (red sand) as a fine aggregate substitution in concrete mix design suitable for commercial environment. The opportunity to achieve low strength concrete using this potential resource for construction applications was also investigated.

The impact on concrete mix design and properties of manufactured concrete were evaluated with a series of laboratory standard tests. The tests conducted in this research were just a few of those possible for assessing the strength and durability behavior of concrete mixes. From the results obtained, the following conclusions are made:

- In order for satisfactory performance in a concrete incorporating Sea water Neutralized Red Sand gave target compressive strength results in excess of the Indian standard requirement, that is 20 MPa, and they were capable of producing adequate compressive strengths for a M20 grade concrete.
- In comparison to concrete using Natural Sand, concrete using Red Sand achieved similar strength characteristics greater than that of the control mix. Partially replaced red sand by the weight of natural sand also showed improved strength in the tests.
- In the case of Red sand replaced concrete mixes (M2, M3, M4, M5, M6), the slump recorded slightly lower values than desirable, especially with the Natural Sand mixes(M1).
- Concrete using Sea water Neutralized Red Sand also showed similar strength characteristics, there were some durability concerns for Sea water Neutralized Red Sand mixes with 12 mm, 10 mm and graded coarse aggregate. The compressive strengths of Red Sand mixes were higher than that of Natural Sand. It seems the trends for all coarse aggregate were almost the same regardless of the fine aggregate used.
- Compressive strength of concrete increased with the increase in sand replacement with different replacement levels of red sand. However, at each replacement level of fine aggregate with red sand, an increase in strength was observed with the increase in age.
- Split Tensile Strength also showed an increase with increase in replacement levels of Red Sand with fine aggregate. Split Tensile Strength also increased with increase in age.
- In the case of M20 concrete mixes, all Red Sand mixes performed similarly better than the control mixes, however there were some concerns in regards to durability indicators.

- From the results obtained, it can be deduced that Red Sand used in M20 grade concrete can achieve increased strengths to an equivalent mix using Natural Sand.
- More importantly, for application in severe environments, it offers improvements in performance for the durability characteristics(water absorption) assessed. Sea water neutralized Red Sand can also achieve similar strengths to traditional concrete and has good durability and a lack of workability when combined with a Red Sand.
- Physical and chemical properties of Red Sand indicate it has similar characteristics to Natural Sand.
- Based on the results of all of the marine grade concrete mixes, the indication is that Red Sand performs better as a replacement of fine aggregate.
- As such, Red Sand showed ability to replace natural materials, when combined with a 10 mm coarse aggregate. Using Red Sand in low strength concrete showed that they do have potential to be used in industry and these material can be a viable sustainable solution to reduce Red Sand stockpiles.

FURTHER STUDIES

Further research is required to explore other aspects of Red Sand concrete. Because of the improved durability performance of Red Sand observed in this investigation, it is recommended that future research is focused on Red Sand for this application. The results presented in this thesis gave an indication of the strength (compressive and tensile) and durability characteristics (water absorption), however in order to enable Red Sand concrete to become accepted as a common construction material, the following experimental studies can be conducted in future with respect to Red Sand concrete-

- The effect of addition of red sand on the durability characteristics of commercial concrete.
- The effect of high temperature on the properties of M20 concrete with red sand.
- The effect of addition of red sand on the shrinkage and the creep properties of concrete.
- Behavior of Red Sand when combined with supplementary cementitious materials (SCM);
- Use of admixtures would be of value if deemed feasible.
- Economic viability of using Red Sand as a fine aggregate in marine grade Concrete.
- Finding an optimal mix by varying the water/cement ratio.

There are many long term effects that need to be assessed when considering a new aggregate for concrete, particularly one that originates from a waste product. Long term effects that need to be assessed are:

- An environmental impact statement should also be conducted. This would explore if there is any leaching from the standard mix design and any

possible environmental impact.

- Effects of using Red Sand on the creep properties of the concrete as the creep results in this research hardly showed a clear trend.
- Fatigue tests in parallel to creep tests to show the suitability of concrete in severe condition;
- A second alkali aggregate reactivity test (different from the one performed in this investigation) as recommended by HB 79; and
- Potential long term reactions between Red Sand and steel reinforcement.

In modern concrete practice the use of admixtures and SCM's has become widespread, particularly in marine and other high performance concrete. To be commercially useful, Red Sand would have to be able to be used with admixtures and SCM's. Investigation into the reaction of using these admixtures and SCM's with Red Sand need to be carried out. In particular the sands need to be trialed more comprehensively with water reducers so that the cement content of the concrete can be reduced to an economic level. The scope of the commercial mixes should be extended as the driving force behind using Red Sand in industry is whether or not it can be done economically. An assessment needs to be made on whether or not Red Sand can be obtained at a cost that makes it viable in industry. In this assessment, consideration needs to be given to the offset in cost as a result of reduced admixture requirements. Since Red Sand is a bulk material, a large factor for consideration is the transport cost, thus while the sand may be economical to use in locations close to the stockpile areas, it may not be economical for locations some distance away. The Red Sand should be trialed with a denser grading of coarse aggregate. The coarse aggregate grading used in this assessment was gap graded, with a large difference between the coarse aggregate and the fine aggregate. Trials with a coarse aggregate graded from 4 and 7 mm to 10, 14 and 20 mm should be assessed. The particle size distribution of the sands, particularly the Low Iron Sand, should be adjusted to find an optimal grading, perhaps with fewer fines, to conform to IS grading curves.

REFERENCE

- [1] ASTM C109/C109 M (Cement Standards and Concrete Standards).
- [2] Barbhuiya S.A, Basheer P.A.M., Clark M.W., Rankin G.I.B, —Effects of seawater-neutralized bauxite refinery residue on properties of concrete, Research Article Cement and Concrete Composites, Volume 33, Issue 6, July 2011, Pages 668-679
- [3] Cooling, DJ, —Improving the Sustainability of Residue Management Practices— Alcoa World Alumina Australia, 5 July 2008.
- [4] Craig klauber, Markus Graife, —Review of Bauxite Re-use Options, Department of Resources, Energy and Tourism (DRET) 2009.
- [5] Glenister DJ, Thornber MR, —Alkalinity of red mud and its applications for management of acid wastes. *Chemica* 1985, pg: 100-113.
- [6] IS 383-1970, Specification for Coarse and Fine Aggregate from Natural Sources for Concrete.
- [7] IS 456-2000, Plain And Reinforced Concrete - Code Of Practice (Fourth Revision).
- [8] IS 516-1959, Methods of tests for strength of Concrete.
- [9] IS 5816-1998, Splitting Tensile Strength of Concrete Method of Test.
- [10] IS 12269-1987, IS Specifications for 53 Grade Ordinary Portland Cement.
- [11] IS 6461 part 1 1972, IS Specifications.
- [12] IS 10262, Durocrete Mix Design Manual.
- [13] Kaveh Soltaninaveh, —The Properties Of Geo Polymer Concrete Incorporating Red Sand As Fine Aggregatel, Master of Science Thesis Curtin University of Technology 2008.
- [14] Kumthekar. M. B, —Application Of Industrial Waste- In The Manufacturing Of Self Compacting Concretel, 2008.
- [15] Majid Ghiafeh Davoodi, Hamid Nikraz,—Chemical and physical characterization of coarse bauxite residue (red sand) for concrete makingl, 2006.
- [16] Majid Ghiafeh Davoodi,—Long Term Stability Of Concrete Made From Red Sand In A Marine Environmentl, PhD Project, Curtin University of Technology, 2008.
- [17] McConchie D, Clark M, Hanahan C,—The use of seawater neutralized bauxite refinery residues in the management of acid sulphate soils, sulphidic mine tailings and acid mine drainage3rd Queensland Environmental Conference: Sustainable Solutions for Industry and Government, Brisbane, QLD; Australia, 2000.pg: 201-208.
- [18] Paramguru RK, Rath PC, Misra VN, Trends in red mud utilization-A Review. *Mineral Processing & Extractive Metall*,2005 Rev. 26, pg : 1-29.
- [19] Peerapong Jitsangiam, PhD Candidate, —Sustainable Use of a Bauxite Residue (red sand) in terms of Roadway Materials, 2008.
- [20] SP 23-1982, Hand book on Concrete Mixes (Based on IS).
- [21] Suchita Rai, K.L. Wasewar, J. Mukhopadhyay, Chang KyooYoo, Hasan Uslu,—Neutralization and utilization of red mud for its better waste managementl *Arch. Environ. Sci.* (2012), 6, pg: 13-33.
- [22] Virotec —Dealing with red mud-By-product of the Bayer process for refining aluminium.*Materials World*. 2003: pg: 22-24.
- [23] Wahyuni, AS, Nikraz, H, Jamieson, E & Cooling, D, —Sustainable Use of Residual Bauxite Tailings Sand (Red Sand) in Concrete", in *Green Processing Conference, The Australasian Institute Of Mining And Metallurgy, Newcastle, Australia.*, 2006.